

BKL System Cattaneo

CM 271S1

max. Ausladung:	27,00 m
Spitzenlast:	700 kg
max. Traglast:	2.500 kg
max. Hakenhöhe:	20,20 m

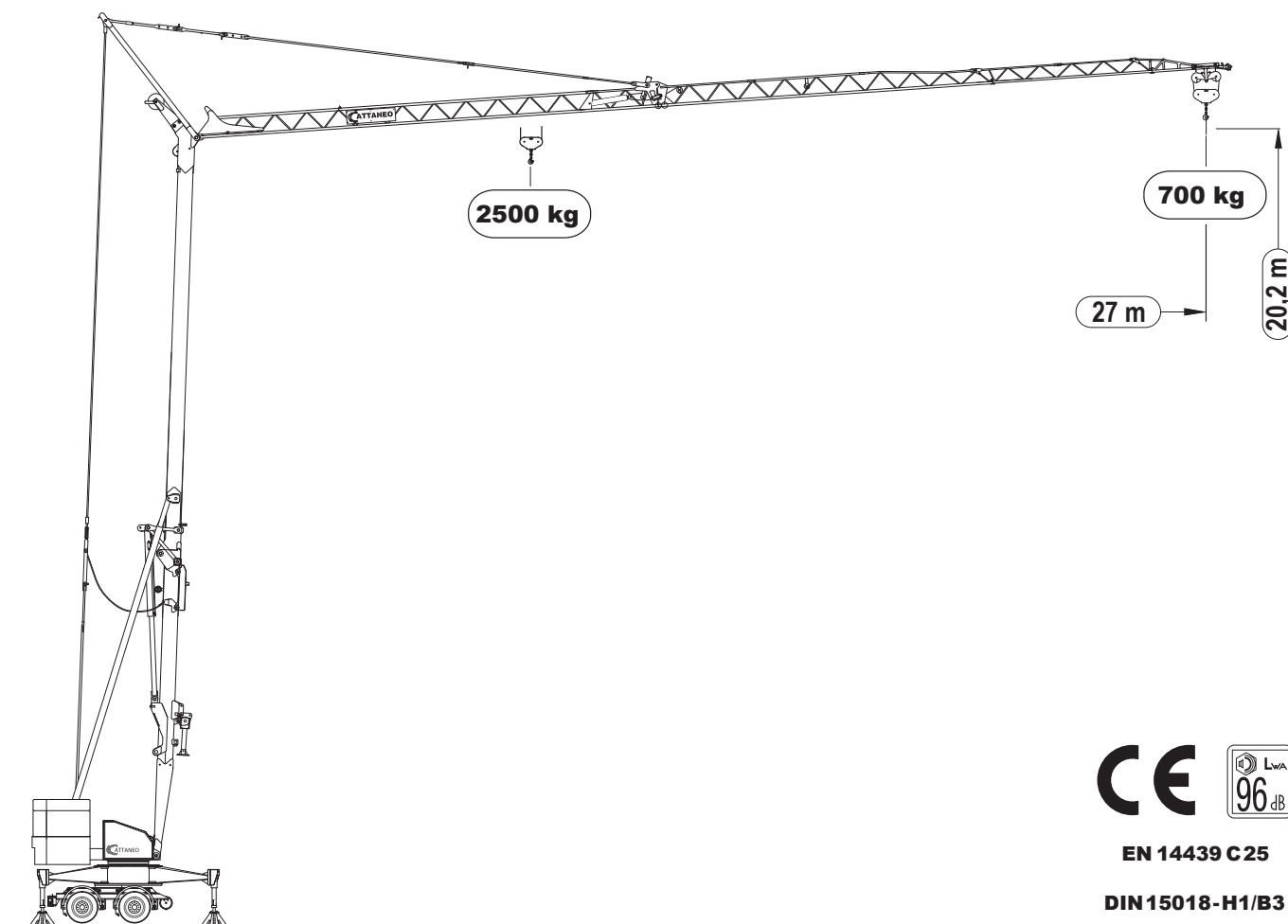

Angaben gemäß Hersteller. Angaben und Informationen ohne Gewähr. Irrtum und Änderung vorbehalten. Haftung ausgeschlossen. September 2022.

BKL SYSTEM CATTANEO CM 271S1

22 mt

 Keine Elektrokomponenten am Ausleger und im oberen Bereich des Krans



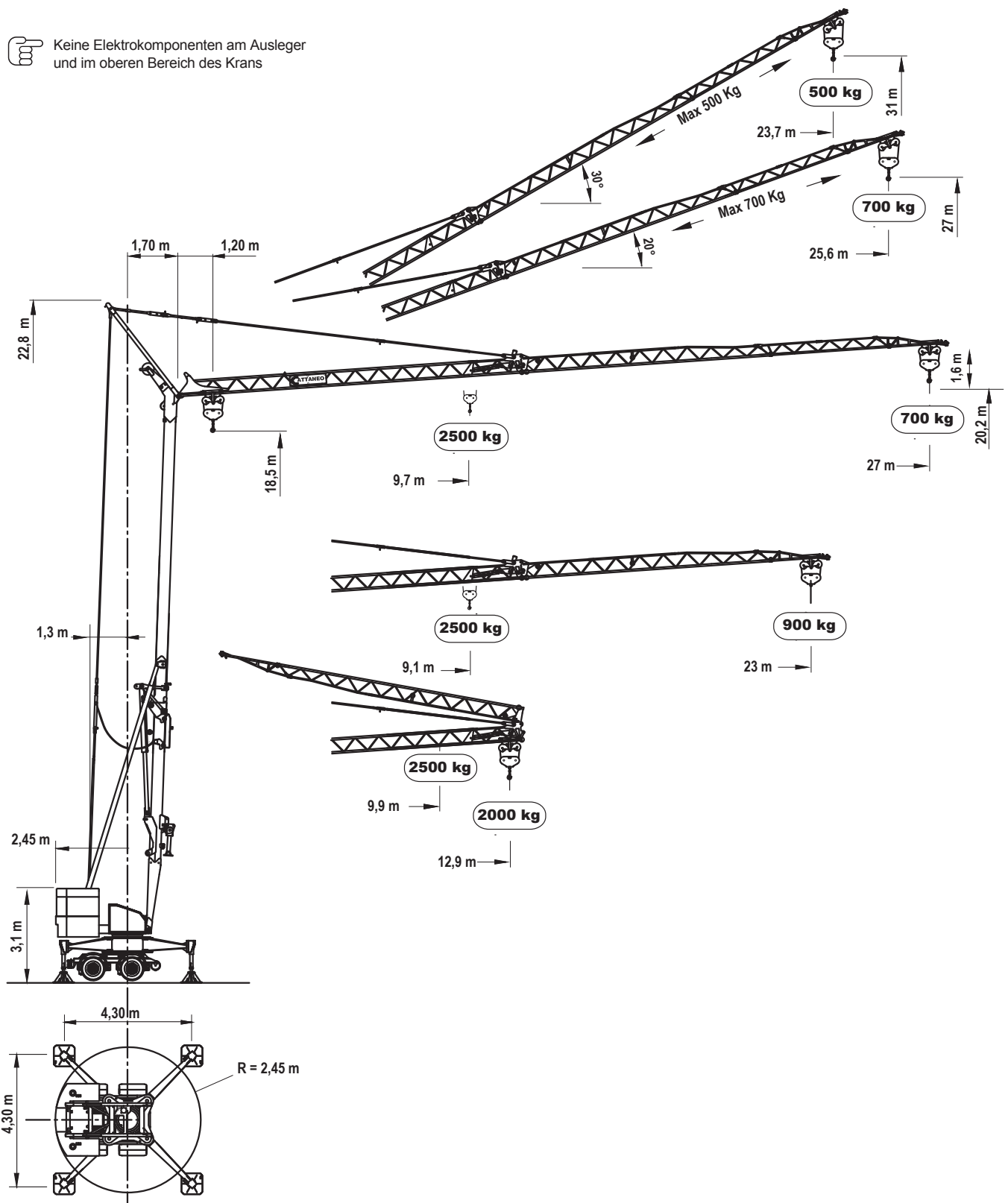



UNTENDREHER



Lastkurven												
	kg	2500	2200	2000	1800	1600	1400	1200	1000	900	800	700
m	9.7	10.7	11.6	12.6	13.9	15.4	17.5	20.3	22.0	24.2	27.0	
m	9.1	11.1	12.0	13.1	14.5	16.0	18.2	21.2	23.0			
m	9.9	11.9	12.9									

Angaben gemäß Hersteller. Angaben und Informationen ohne Gewähr. Irrtum und Änderung vorbehalten. Haftung ausgeschlossen. September 2022.

Leistungen / Performance

				 400V - 50Hz 10 kW (12,5 kVA)				
	inverter	kW/g/min		1°	2°	3°	4°	
				m/min	5	18	30	40
				kg	2.500	2.500	1500	1000
	inverter	3/1400		m/min	25 - 50			
	inverter	2,2/1400		g/min	0,4 - 0,9			

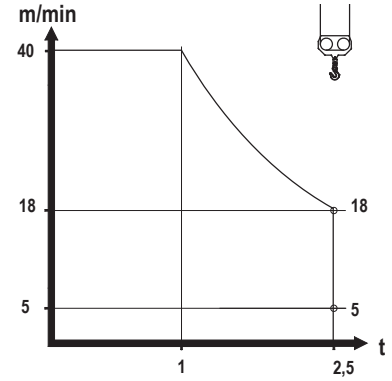

Aufstellvorgang / Erection procedure

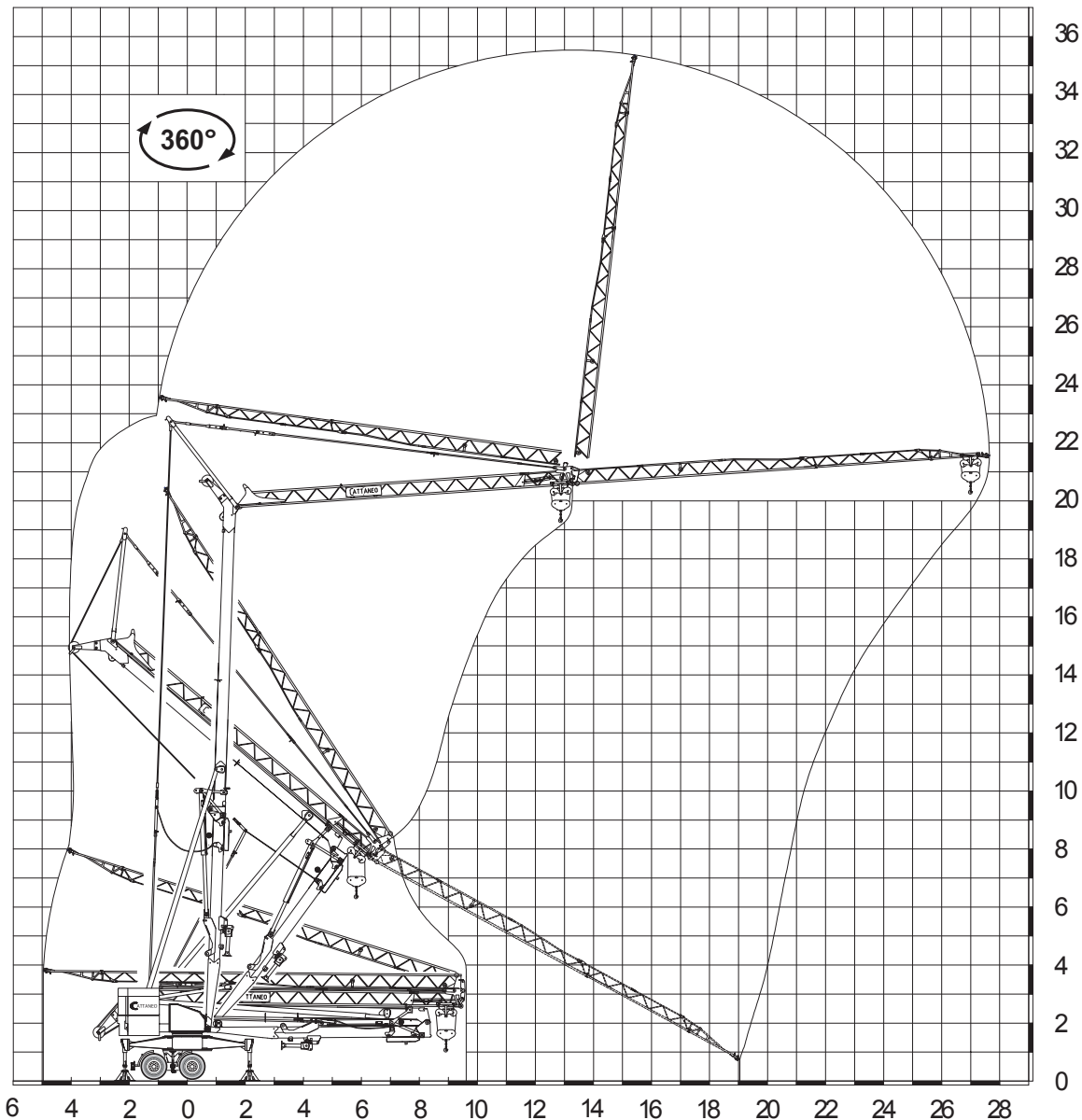

Angaben gemäß Hersteller. Angaben und Informationen ohne Gewähr. Irrtum und Änderung vorbehalten. Haftung ausgeschlossen. September 2022.

Gegengewicht aus Betonplatten / Ferro-concrete ballast slabs

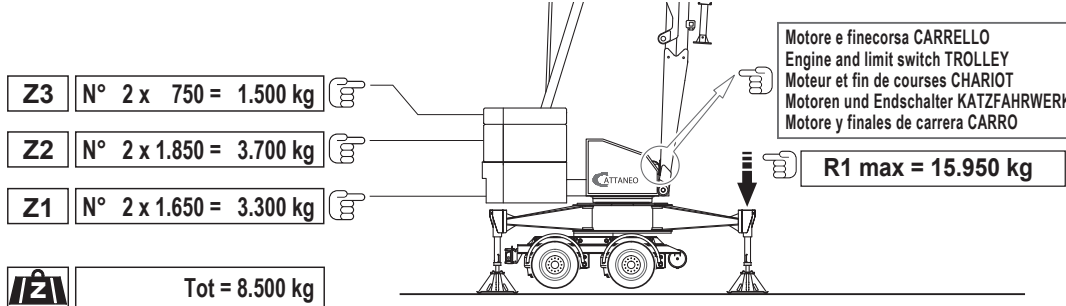

Transport / Transport

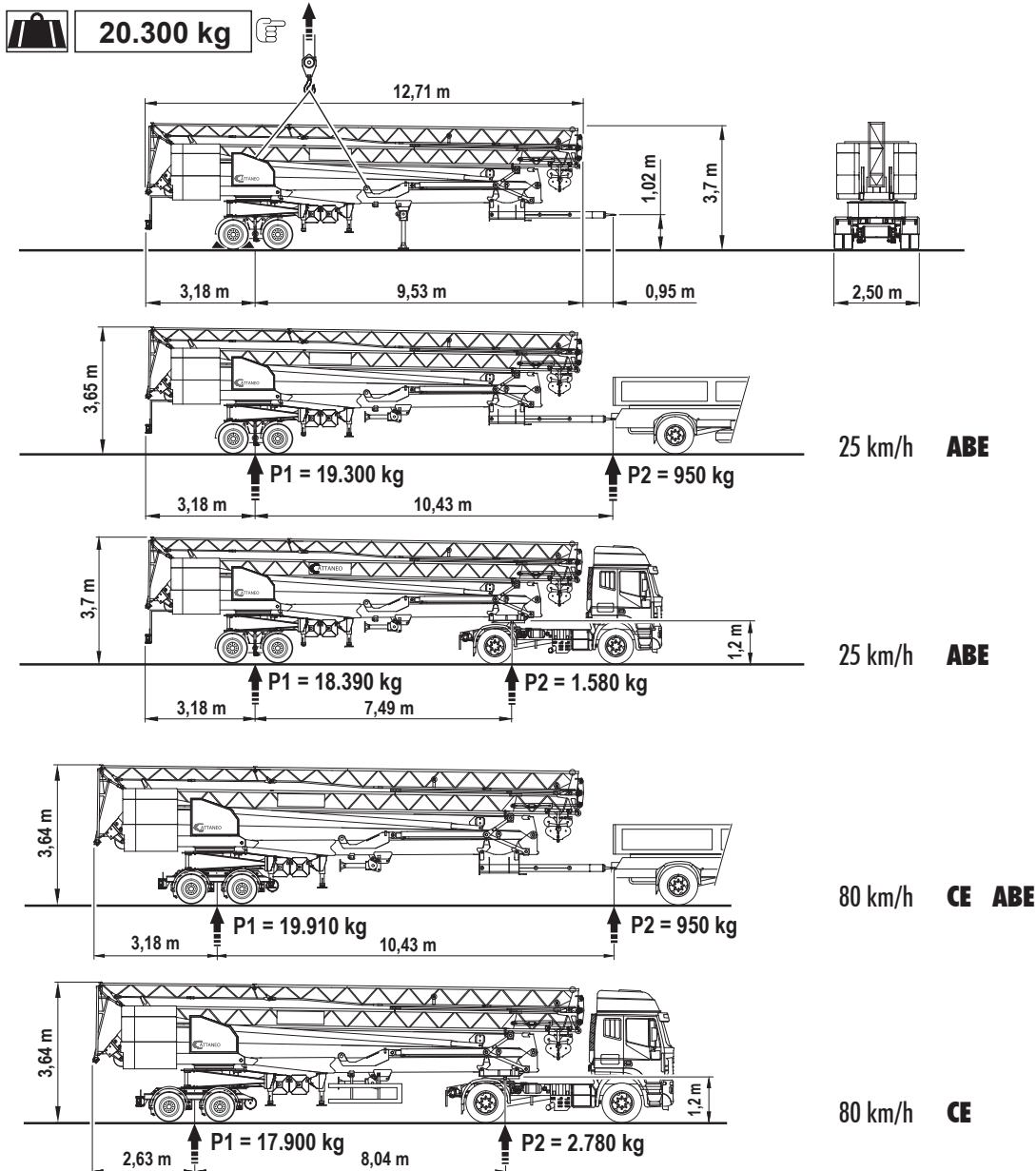

Angaben gemäß Hersteller. Angaben und Informationen ohne Gewähr. Irrtum und Änderung vorbehalten. Haftung ausgeschlossen. September 2022.